

Vorsphere™

AIROLUSION Ltd have developed a range of Blast Containment Vessels to Mitigate the blast & fragmentation from IED's (*improvised explosive devices*), EOD's (*Explosive Ordnance Disposal*), Anti-Personnel & Anti-Tank mines, Mortars & ERW (*Explosive Remnants of War*).

● Containment

The **Vorsphere™** is designed to be a Portable, Reusable, Cost Effective, Explosion proof apparatus.

The **Vorsphere™** will Safely Contain & Remove Explosive Devices. It will allow the Safe Detonation without the threat to Life, Land or Buildings.

The **Vorsphere™** will Ensure the surrounding environment is protected from damage or contamination.

● Mitigation Objective

Airolusion's primary objectives were to produce a re-usable apparatus that will Mitigate explosive devices without causing harm or damage to the environment and without allowing any fragmentation.

Airolusion wanted to ensure that it could be readily manufactured in varying sizes & it could be designed to be made as a cost effective disposable unit or an indefinite re-usable tool. It wanted to Ensure that the apparatus did not need to be secured to the ground or a transport unit.

● Blast Material & Technology

The **Vorsphere™** was designed to be manufactured in metal & or a composite material dependent on its required application, field of operation, durability and intended longevity. It was also paramount that the use of high technology was minimised to enable ease of manufacture, allow repairs to be undertaken in the field if necessary and requiring minimal skill to transport and operate. Ensure any Blast Material and or Fragmentation is securely contained.

● IED Clearance

The **Vorsphere™** will offer troops in the field a tool that will contain and remove IED's efficiently & cost effectively, preventing Harm & or Damage to Property, without contaminating the Land or the Environment.

● Mine Field Clearance

- 1 The **Vorsphere™** is environmentally friendly by initially ensuring the safety of the community and the operational staff.
- 2 By safely clearing mine field explosive devices to a safer environment and / or containing any detonation.
- 3 Ensuring no trace of the device remains to contaminate land or water supplies.



- 4 Preventing damage to the natural habitats of wildlife & vegetation and protecting remnants of historical and cultural significance.

● Mine Field Reclamation

The **Vorsphere™** ensures Mine Field land & property is free from damage or contamination. Structures are stable; the Land is level & vegetation undamaged, which allows the instant cohabitation of the community and livestock.

● EOD & ERW

The **Vorsphere™** can be utilised in the field of EOD and to remove & contain ERW.

● Adaptability

The **Vorsphere™** Blast Containment device is extremely Adaptable and flexible and has a range of additional uses.

- Besides its Military and Mine Field applications it is perfectly suitable for use by the security and postal services as a bombproof container.
- It can be used to safely transport explosives.
- It is ideal as a bombproof trashcan / litterbin.

● Flexibility

Due to its design, shape & its constituent make up the **Vorsphere™** can act as an ideal Check Point / Traffic Bollard. It can be modelled and act as a Litterbin, Planter or Flag Standard.

Vorsphere™ Technical Specifications:

PRODUCT	Height x Diameter	Height x Diameter	Material	Containment Specification
	Metric	Inches		
Vorsphere™ Vantage	720 x 700 mm	28.3" x 27.5"	Steel	1.4-2kg C4 or PE4
Vorsphere™ Valour	1020 x 1000 mm	40" x 39.3"	Steel	2-4kg C4 or PE4
Vorsphere™ Venturer	1020 x 1000 mm	40" x 39.3"	Steel	3-5kg C4 or PE4
Vorsphere™ Vanquish	1200 x 1180 mm	47.2" x 46.4"	Steel	4-6kg C4 or PE4
Vorsphere™ Victory	1520 x 1500 mm	59.8" x 59"	Steel	6-8kg C4 or PE4

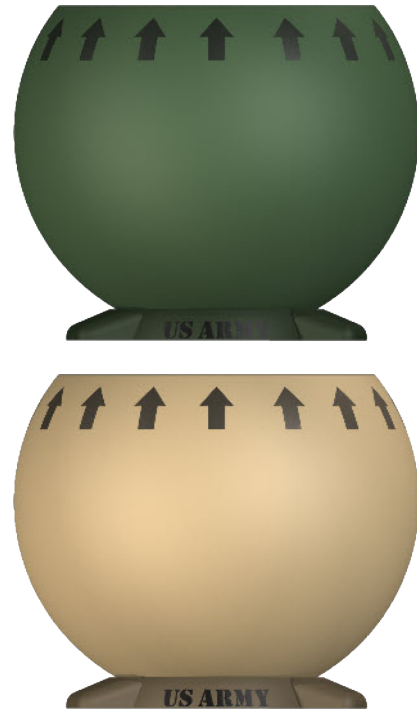
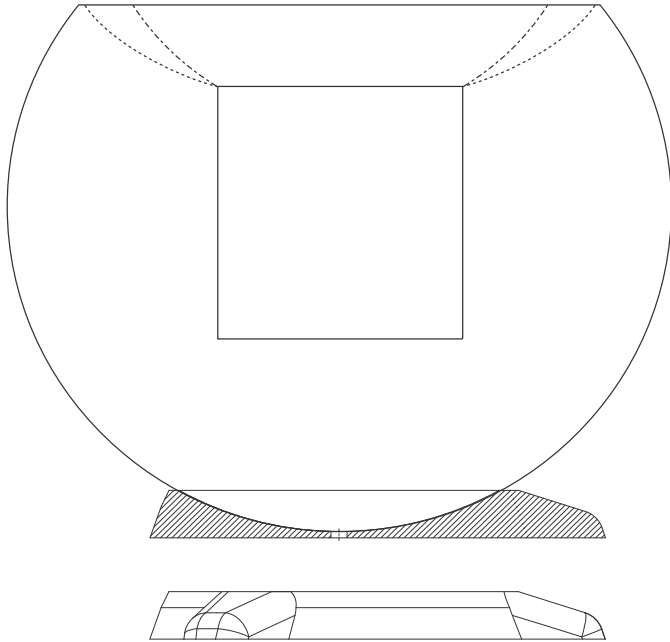

Fig: Example finish options. Custom finishes available on request.

Procurement

Airolusion will supply a range of standard containment units for general field operations within the Military or Civilian environment, or will supply bespoke specification units to order.

All enquiries to: ***Airolusion Ltd***
The Plaza, 100 Old Hall Street, Liverpool.
L3 9QJ United Kingdom

Tel: +44 (0) 781 806 5008

Fax: +44 (0) 700 608 1519

Email: info@airolusion.com

mail@airolusion.com

Website: www.airolusion.com